



# Schwienbacher Abbruch Technik

Werkstatt • Lager • Service seit 1977

## D-82229 Seefeld (bei München)

Graf-Toerring-Seefeld-Strasse 9b / 17

Tel. 08152 / 998 969-0 Fax.- 9

### T.50 STANDARDLÖFFEL *optimal\** für Bagger von 9,6 bis 12,5 to

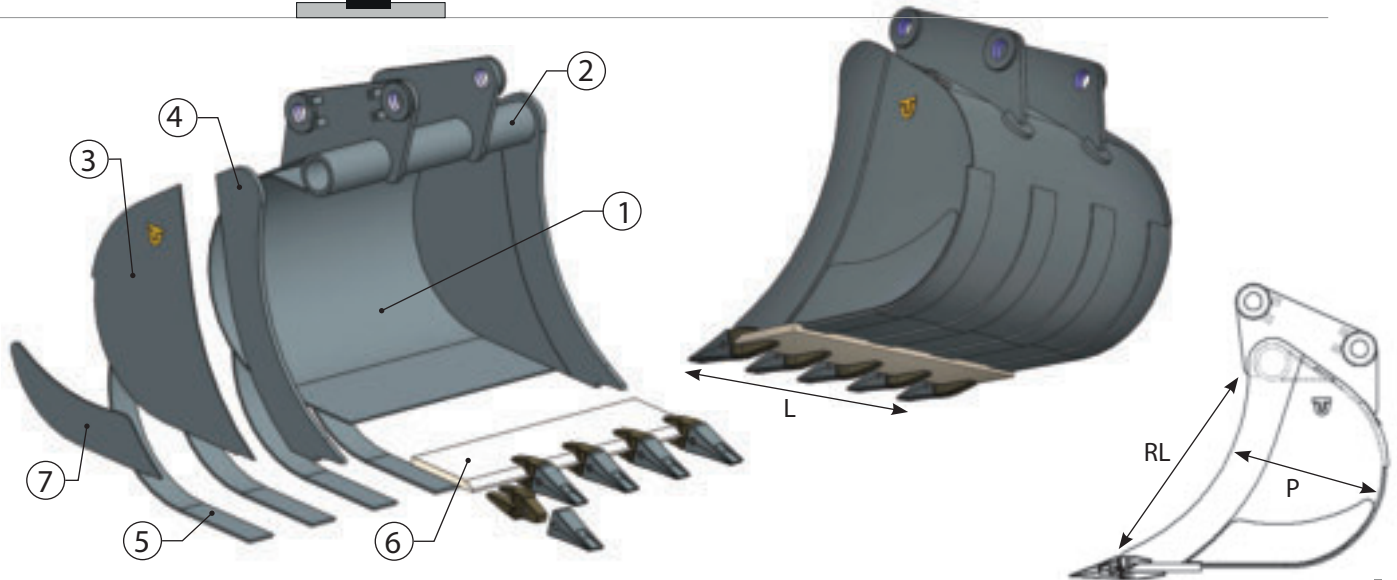
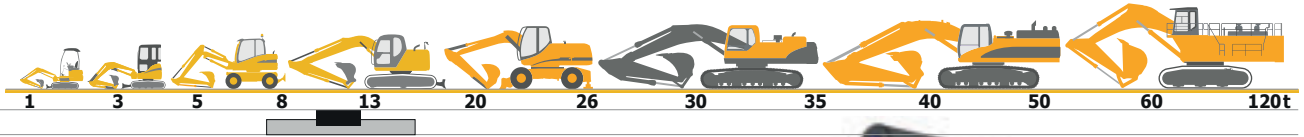

Classe Class	Codice Code	L mm	Cap. SAE Lt	Denti n° Teeth	Peso Kg Weight	RL mm	P mm	CAT J220	FEURST FK3 TLR	ESCO U20 S
T.50 9,6 - 12,5 ton	WSD050-030	300	80	2	164	805	530	1.336,00	1.458,00	1.540,00
	WSD050-040	400	123	3	184			1.482,00	1.616,00	1.774,00
	WSD050-050	500	168	3	207			1.664,00	1.816,00	1.960,00
	WSD050-060	600	215	4	227			1.732,00	1.888,00	2.112,00
	WSD050-070	700	263	4	253			1.844,00	2.012,00	2.230,00
	WSD050-080	800	320	5	275			1.946,00	2.124,00	2.332,00
	WSD050-090	900	370	5	302			2.044,00	2.230,00	2.550,00
	WSD050-100	1000	421	5	325			2.240,00	2.444,00	2.754,00
	WSD050-110	1100	473	6	340			2.336,00	2.548,00	2.936,00
	WSD050-120	1200	525	6	360			2.496,00	2.724,00	3.102,00
		1	2	3	4	5	6	7	8	
Materiale	Material	S355	S355	S355	S355	S355	EN 250	S355	/	
Spessore	Thickness	6 mm	127 x 14 mm	6 mm	20 mm	8 mm	250 x 25 mm	6 mm	/	



# Schwienbacher Abbruch Technik

Werkstatt • Lager • Service seit 1977

## D-82229 Seefeld (bei München)

Graf-Toerring-Seefeld-Strasse 9b / 17

Tel. 08152 / 998 969-0 Fax.- 9

### T.50 STANDARDLÖFFEL *optimal\** für Bagger von 9,6 bis 12,5 t

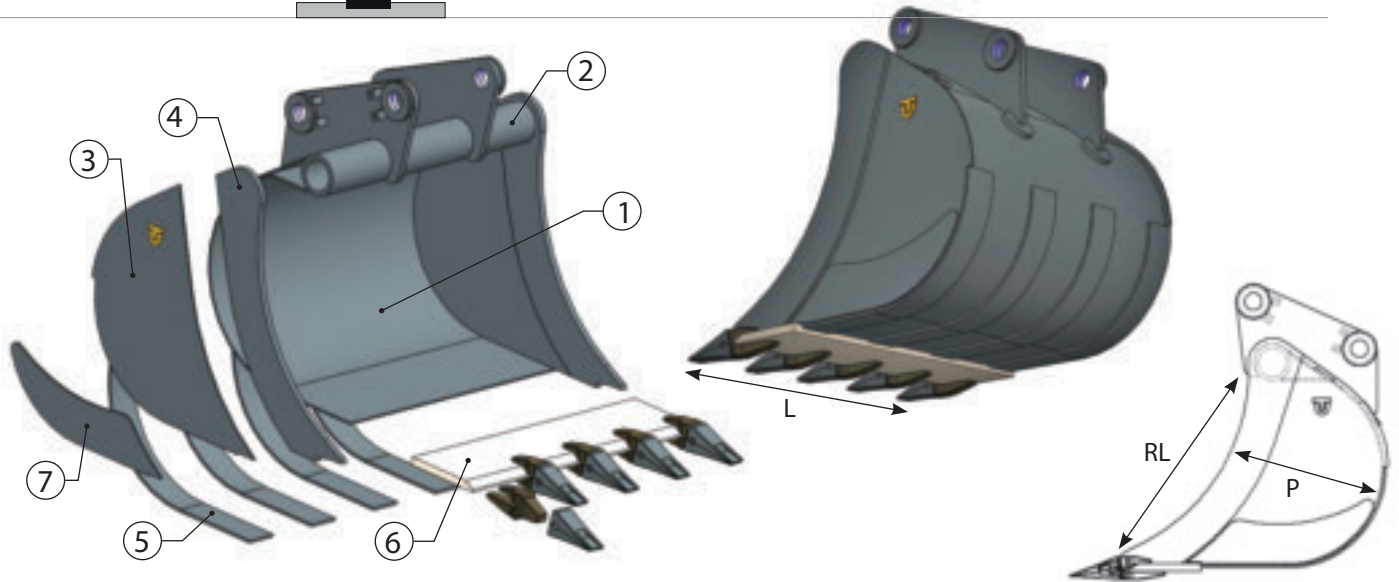
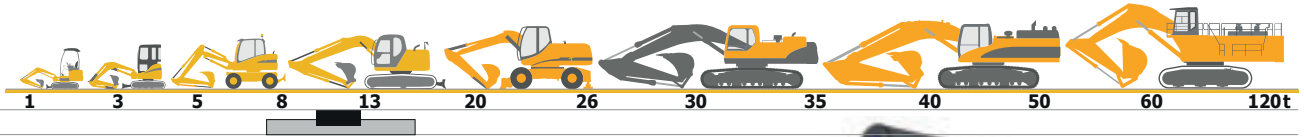

### T.50 \* *optimal* = für Bagger von 9,6 bis 12,5 t mit Standard-Ausrüstung.

**AKERMANN** H 3B \* **ATLAS** 1104, 1204 \* **BENATI** 3.12R \* **BENFRA** 3R, 3C \* **BOBCAT** 444 \* **CASE** WX 120, 488 \* **CATERPILLAR** 311 FLRR \* **COSMOTER** BAT10 0 \* **EUROMACH** 9000, 9500 \* **FIAT HITACHI** FH 115W, FH 120W, EX 100, FH 115, FH 125W \* **FIAT KOBELCO** E 115SR, EX 125W \* **HYUNDAI** R 110LC7 \* **JCB** JS 110, JZ 115, 100C, HYDROADIG 110W \* **KOBELCO** SK 100, SK 115SR \* **KOMATSU** PC 110R, PC 110R1, PW 110R, PW 118, PC 118, PC 118MR-8, PW 98MR-8, PW 118MR-8 \* **LALTESI** 40/111 \* **LIEBHERR** A 309, A 310, A 311, A 910CPT LIT \* **Macmoter** M 12M/BW 110 \* **MECALAC** 14 MX, 14 MBX, 12 MTX \* **NEW HOLLAND** MH 2.6, MH 3.6, E 115SR \* **O&K** MH 2.10/MH 3.5; PMI 450/810R/913 \* **TEREX** HR 42, TW 110, TC 125 \* **VENERI** VF 10.23D \* **MF** 250 \* **WACKER NEUSON** 11002 RD, 12002 RD, 1454, EW 100 \* **YANMAR** Vio 100, SV 100-2, SV 100-2PB

**geeignet** = für Bagger von 7,5 bis 16 t je nach Ausrüstung.

Andere **Klassen/Größen** bedingt geeignet. Bei Bedarf bitte anfragen!