



Schwiebacher Abbruch Technik

Werkstatt • Lager • Service seit 1977

D-82229 Seefeld (bei München)

Graf-Toerring-Seefeld-Strasse 9b / 17

Tel. 08152 / 998 969-0 Fax.- 9

T.48 STANDARDLÖFFEL *optimal** für Bagger von 7,1 bis 9,5 to

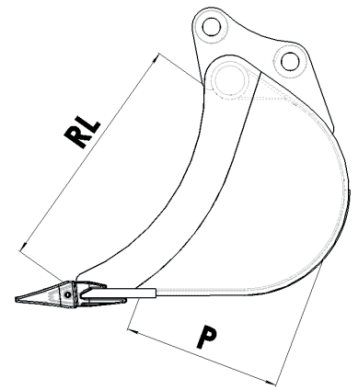
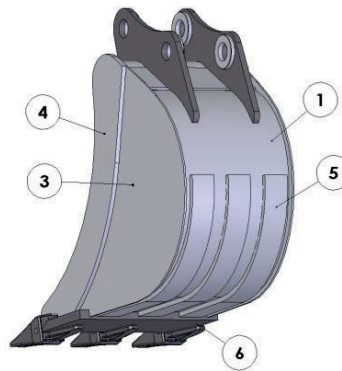
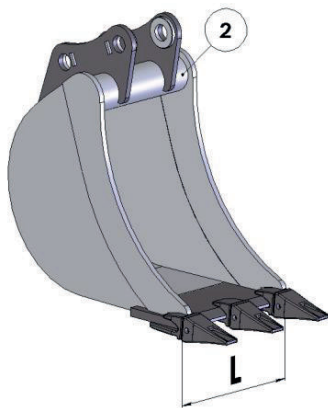
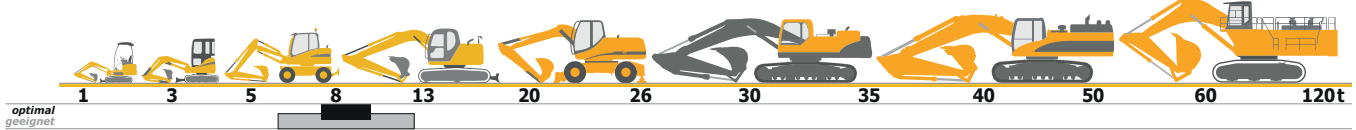

Klasse Class Classe	Bestell Nr. Code Code	L mm.	Cap. SAE Lt.	Zähne Teeth Dents	Gewicht kg Weight Poids	RL mm.	P mm.	Zahn – Teeth – Dents €	
								C 04	Esco V17 SYL
T.48 7,1-9,5 Ton	T48ST0030	300	86	2	112	750	500		
	T48ST0035	350	105	3	122				
	T48ST0040	400	125	3	136				
	T48ST0045	450	146	3	146				
	T48ST0050	500	167	3	153				
	T48ST0060	600	209	4	169				
	T48ST0070	700	252	4	190				
	T48ST0080	800	296	4	205				
	T48ST0090	900	340	5	220				
	T48ST0100	1000	384	6	239				
		1	2	3	4	5	6	7	8
Material	<i>Material Matériel</i>	Fe 510	Fe 510	Fe 510	Fe 510	Fe 510	En 250	Fe 510	/
Stärke	<i>Thickness Espessure</i>	6 mm	121 x 14 mm	6 mm	20 mm	70 x 8 mm	200 x 25 mm	6 mm	/

*optimal = für Bagger von 7,1 bis 9,5 t mit Standard-Ausrüstung.

Atlas 1004/1102D; **Benati** 3.06/3.07R/3.08R/5.08/5.10; **BobCAT** 442; **Case** 488/9007/WX 90/WX 95/CX 75/CX 75SR/CX 80; **Caterpillar** E 307/E 70/E 70B/307C/308C CR; **Daewoo Doosan** 070-III/075-V; **Eurocomach** ES-800; **Euromach** 8500/TIGRONE; **Fai** 409/410C/W/750 C/900CH/GTH/GTV; **Fiat Hitachi** EX 60/EX 60.5/E X 60WD/FH 65W/EX 75U R/EX 75US/FH 85W/FH 9 0WT/FH 95; **Fiat Kobelco** E 70SR/E 80 SR; **Hanix** H 75B; **Hitachi** ZX 70/ZX 80SB/ZX 85US; **Hydrema** R 800; **Hyundai** R 95W-3; **Ihi-Imer** 80 NX/80NX3; JCB JS 70/JZ 70/8080ZTS; **Kamo** MOBIL 70; **Kobelco** SK 75UR/SK 80 MSR/YUTANI SK 03; **Komatsu** PC 75/75R/PC 75R2/PC 75UU/PC 75UU/PC 78MR6/PC 95R/PC 95R2/PW 75/PW 95/PC 58U; **Kubota** KX 251; **Kramer** 806/808; **Liebherr** A 307/A 308/R 308; **Macmoter** M 7/M 8/M 8M/M 10/BW 75/BW 95; **Mecalac** 11CX/12CX/12MX/12MSX; **Neuson** 7002RD/8002RD/75Z3; **New Holland** E 80MS R; O&K 2.8C/2.8D/MH 2.5; **Schaeff** HR 41/HML 40/HML 41/HML 42/HS 40A/B/D/HS 41/SKB 1000; **Takeuchi** TB 80FR/TB 175/TB 175W; **Terex** 960/970; **Venieri** VF 12.23; **Volvo** E CR 88; **Yanmar** Vio 75/Vio 100.

geeignet = für Bagger von 6,0 bis 12,5 t je nach Ausrüstung.
Andere Klassen/Größen bedingt geeignet. Bei Bedarf bitte anfragen!