



# Schwiebacher Abbruch Technik

Werkstatt • Lager • Service seit 1977

## D-82229 Seefeld (bei München)

Graf-Toerring-Seefeld-Strasse 9b / 17

Tel. 08152 / 998 969-0 Fax.- 9

### T.35 STANDARDLÖFFEL *optimal\** für Bagger von 4,0 bis 5,2 to

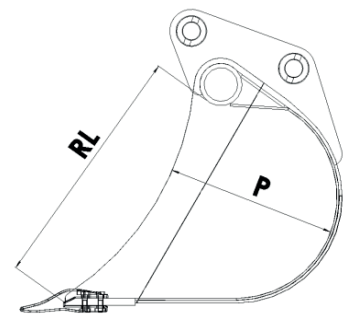
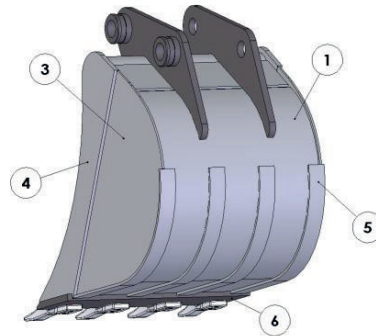
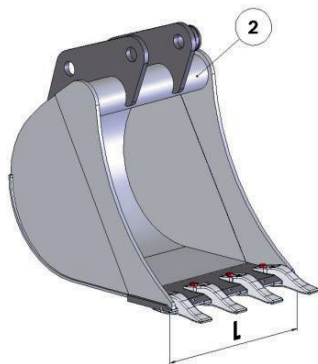
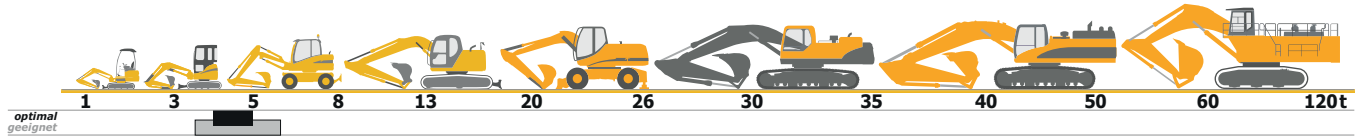

Klasse Class Classe	Bestell Nr. Code Code	L mm.	Cap. SAE Lt.	Zähne Teeth Dents	Gewicht kg Weight Poids	RL mm.	P mm.	Zahn – Teeth – Dents €	
								B 335	Esco V13 SYL
<b>T.35</b> <b>4,0-5,2</b> <b>Ton</b>	T35ST0030	300	56	3	72	600	400		
	T35ST0035	350	69	3	80				
	T35ST0040	400	83	3	86				
	T35ST0045	450	97	4	92				
	T35ST0050	500	111	4	98				
	T35ST0060	600	139	5	116				
	T35ST0070	700	167	5	127				
	T35ST0080	800	196	5	140				
	T35ST0090	900	224	5	153				
	T35ST0100	1000	252	6	165				
		<b>1</b>	<b>2</b>	<b>3</b>	<b>4</b>	<b>5</b>	<b>6</b>	<b>7</b>	<b>8</b>
<b>Material</b>	<b>Material Matériel</b>	Fe 510	Fe 510	Fe 510	Fe 510	Fe 510	En 250	/	/
<b>Stärke</b>	<b>Thickness Espessure</b>	6 mm	89 x 10 mm	6 mm	15 mm	50 x 8 mm	200 x 20 mm	/	/

*\*optimal = für Bagger von 4,0 bis 5,2 t mit Standard-Ausrüstung.*

**Airmann** AX 40.2/AX 40U; **Atlas** AM 48R/0 605, 804; **Benati** M 35; **Benfra** 1.25/2500/E 4/E 4L/E 5; **BobCAT** X335/337/341/430;  
**Case** CK 50/CX 40B/CX 50B/50/52; **Caterpillar** 304.5/304CR/305.5/305CR; **Cimas** FR 280; **Euromach** 4500/5500;  
**Eurotom** TS 45; **Fai** 245/250; **Fermec** 150; **Fiat Hitachi** EX 40/EX 40.2/EX 40U/FH 40/FH 40.2; **Fiat Kobelco** E 40SR/E 40.2SR/  
E 45SR/E 50.2SR; **Fiori** FA 700; **Hanix** N 450/S&B 30/H 45A/H 45B; **Hinowa** DM 40L/VT 4000; **Hitachi** ZX 40/ZX 40U-2;  
**Hyundai** 45; **Ihi-Imer** 40J/40JX/45J/45N/40NX/45 NX/45J5; **JCB** 2DX/8050/8052; **Kobelco** SK 40/SK 40SR/SK 042/SK 45SR/  
SK 45 SR.2/SK 050/SK 50SR.3/S K 50UR; **Komatsu** PC 40/40.1.2.3.5.6.7/PC 40MRX/45/45.7/4 5R/PC 45R8/PC 50MR2/PC 50UU/55U;  
**Kubota** KX 151/KH 130/KH 55/KX 040/KX 0 45/U 45/U 45-3; **Libra** 145; **Macmoter** M 5/M 5M/M 5S/BW 50; **MF** 150;  
**Neuson** 50 Z3RD/5 001RD/5002/5002RD/55 01 WD; **New Holland** E 40.2SR/E 50.2SR; **Nissan** H 45A/N 450.2;  
**O&K** RH 1.45/1.48; **Palazzani** PB 40/PB 50; **Pel Job** EB 406/EB 450/EC 450/EB 502/EB 506; **Schaeff** HR 18/HR 20;  
**Takeuchi** TB 045/TB 145/TB 53FR/TB 55UR; **Terex** HR 18/HR 20; **Venieri** VF 2.23/VF 3.85/VF 4.35/VF 4.45/VF 5.45/VF 6.23;  
**Volvo** EC 45/EC 45 PRO/EC 50/E W 50; **Yanmar** B 50/B 50 V/B 50W/Vio 40/Vio 45/Vio 50V/Vio 55VCR.

geeignet = für Bagger von 3,5 bis 6,0 t je nach Ausrüstung. Andere Klassen/Größen bedingt geeignet. Bei Bedarf bitte anfragen!