



# Schwiebacher Abbruch Technik

Werkstatt • Lager • Service seit 1977

**D-82229 Seefeld** (bei München)

Graf-Toerring-Seefeld-Strasse 9b / 17

**Tel. 08152 / 998 969-0 Fax.- 9**

## T.20 STANDARDLÖFFEL *optimal\** für Bagger von 1,2 bis 1,8 to

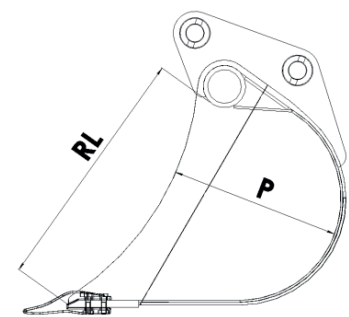
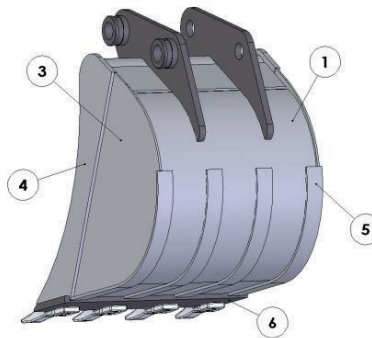
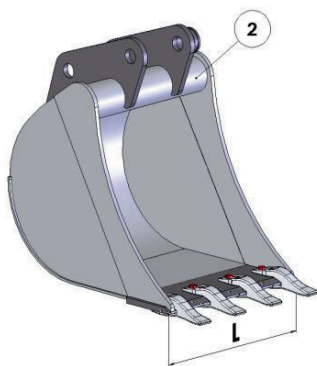
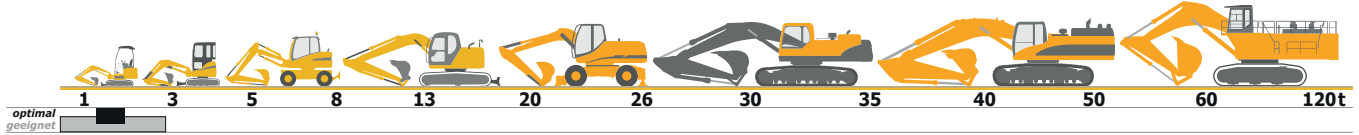

Klasse Class Classe	Bestell Nr. Code Code	L mm.	Cap. SAE Lt.	Zähne Teeth Dents	Gewicht kg Weight Poids	RL mm.	P mm.	Zahn – Teeth – Dents €	
								B 1000	Esco V13 SYL
<b>T.20</b> <b>1,2-1,8</b> <b>ton</b>	T20ST0020	200	14	2	28	380	265		
	T20ST0025	250	19	2	32				
	T20ST0030	300	25	3	34				
	T20ST0035	350	30	3	36				
	T20ST0040	400	36	3	41				
	T20ST0045	450	42	4	44				
	T20ST0050	500	47	4	46				
	T20ST0060	600	58	5	53				
	T20ST0070	700	70	5	60				
		<b>1</b>	<b>2</b>	<b>3</b>	<b>4</b>	<b>5</b>	<b>6</b>	<b>7</b>	<b>8</b>
<b>Material</b>	<b>Material Matériel</b>	Fe 510	Fe 510	Fe 510	Fe 510	Fe 510	En 250	/	/
<b>Stärke</b>	<b>Thickness E spessore</b>	4 mm	60 x 8 mm	4 mm	10 mm	30 x 5 mm	150 x 16 mm	/	/

\*optimal = für Bagger von 1,2 bis 1,8 t mit Standard-Ausrüstung.

**Airmann** HM 10/15/AX 12/15/17/AX 15.2/1 7.2/UE 10/12/15; **Atlas** AB 100/AB 1 20/404/AM 16R/AM 21 R; **Benati** M 13/M 14/M 15; **Benfra** 9.01/901B; **BobCAT** X120/X220/320/322/323/E 14/ E 16/E 18; **Case** 15/16/ CK 13/CK 15/CK 16/CX 15/CX 16B/CX 18 B/CX 20B; **Caterpillar** 301.5/301.6/301.7/301.8; **Daewoo Doosan** 015/018/DX 15/DX 18; **Dinapac** VD 15/VD 151/VD 16; **Eurocomach** ES 150SR/ES 180/ES 150.2/ES 180.2/ES 150.3/ES 150.4/ES180.4/ES 180SR; **Eurocomach** E 1200/E 1300/E 1 500 S/E 1800/E 250/E 280/E 300/RT-725/RT-728/E 235K/ET 245K; **Eurotom** TS 20; **Fai** 212/215/218; **Fermec** 114/115; **Fiat Hitachi** UE 10/12/15/EX 12/15/FH 15/16/17/FH 15.2/16.2/17.2; **Fiat Kobelco** E 15/E 16/E 17SR/E 18; **Foredil** 3.15/3.18/FM 16/FM 18V/FM 19VR; **Gehlmax** MB 135/138/145/148/A 12, A 14SA; **Hanix** H 12A/H 15 A/H 15B.2/H 16D/H 17D/N 120/N 150/N 150.2; **Hinowa** D 10/13/15/VT 1550/VT 1650/DM 10/DM 13/DM 15; **Hitachi** ZX 10-U2/ZX 14-3/ZX 16/ZX 17/ZX 18; **Hydromac** 15; **Hyundai** 15-7/R 16-9; **Ihi-Imer** 10G/12G/12JX/14G/14NXT/15J/15NX/16 NXT/16ND/17JE/17NE/18J/18NXT; **Imef** HE 12/14/16/18/HE 14S/16S/HE 1.15/HE 1.16/HE 1.18; **JCB** 801/801.2/801.4/801.5/801.6/801.7/801.8; **Kamo** 3X BABY; **Kobelco** SK 012/SK 013/SK 015/SK 16MSR/SK 17; **Komatsu** PC 05/07/PC 12R/PC 12R8/PC 14R/PC 15R/PC 15R8/PC 16R/PC 18MR-2/MIS TRAL; **Kubota** KH 21/31/35/36/KX 016-4/U 17-3/KX 018-4/KX 019-4/KX 31/KX 36/36.2/KX 41/41.2S/41.2V/41.3/K 013/U 1T5.2/ RO 310; **Libra** 114/116/118/115T/116S/118S/216S/218SV/219RSV; **Macmoter** M 1/M 1S; **Mazotti** MAF 21 1; **Messersi** M 16/18/20; MF 114/115; **Neumeier Yuchai** NR 1.5/NR 1.6/NR 1.8/NR 1.8K; **Neuson Wacker** 1200RD/1302RD/1402RD/1404/1500/1501RD/1502RD/1403/1503; **New Holland** E 10/E 16/E 18; **Nissan** 06/080.2/120/140/N 150/N 150.2/H 15; **O&K** RH 1.1/1.2/1.15/1.17/1.20; **Pel Job** EB 10/11/12/12.4/14.4/15/EB 150/EB 150 XR/Sirius; **Sunward** SWE 17/SWE 18; **Schaeff** HR 12/HR 13/HR 1.6/HR 2.0; **Takeuchi** TB 014/TB 15/TB 015/TB 16/TB 15FR/TB 016; **Terex** HR 1.5/HR 1.6/HR 2.0/TC 10/TC 15/TC 16/TC 20; **Venieri** VF 121/VF 141/VF 11/VF 171; **Volvo** EC 13XR/EC 13XTV/EC 14/EC 15/EC 15B/EC 15BXR/EC 15XTV/EC 17/EC 18/EC 20/EC 20BXT/TE.2C0 20BXTV; **Yanmar** B 12/B 12.3/B 14/B 15-3/B 15EX/B 17/B 18/B 18E X/121/Vio 15/SV 15/SV 17; **Ygri** Y 12/Y 14/Y 15/Y 1 8/M 120/SA 140/A 160/SA 170.

geeignet = für Bagger von 0,6 bis 2,8 t je nach Ausrüstung. Andere Klassen/Größen bedingt geeignet. Bei Bedarf bitte anfragen!