



Schwiebacher Abbruch Technik

Werkstatt • Lager • Service seit 1977

D-82229 Seefeld (bei München)

Graf-Toerring-Seefeld-Strasse 9b / 17

Tel. 08152 / 998 969-0 Fax.- 9

T.25 DRAINAGE-LÖFFEL *optimal** für Bagger von 1,9 bis 2,8 to

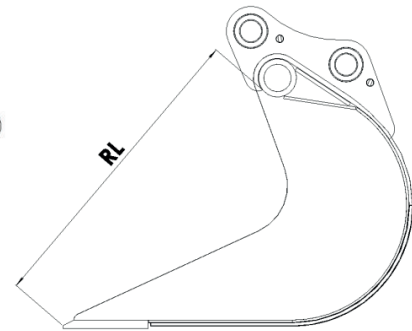
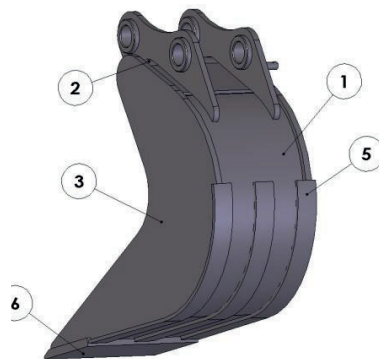
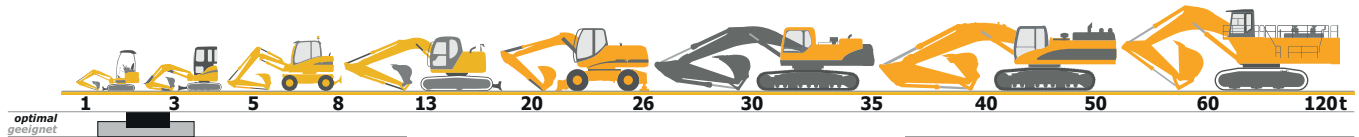

Klasse Class Classe	Bestell Nr. Code Code	Gewicht kg Weight Poids	L mm.			RL mm.		Preis Price List Tarif
T.25 1,9 - 2,8 ton	T25ME0480	~ 46	250 / 300			480		
		1	2	3	4	5	6	
Material	Material Matériel	Fe 510	Fe 510	Fe 510	/	Fe 510	En 250	
Materialstärke	Thickness Eaisseur	5 mm	67 x 8 mm	8 mm	/	30 x 5 mm	150 x 16 mm	

*optimal = für Bagger von 1,9 bis 2,8 t mit Standard-Ausrüstung.

Airmann AX 22/AX 22.2/AX 25/HM 20; **Benati** M 25; **Benfra** 9.02/E 105; **BobCAT** 730/X225/325/328; **Case** CK 25/CK 28/CX 22B/CX 23/CX 27B/CX 28/23/28; CRS 18/20/25; **Euromach** SUPER JOLLY; **Eurotom** TS 15S; **FAI** 220/222/226; **Fermec** 123/128; **Fiat Hitachi** EX 22/25/FH 22/22.2/25.2/UE 20/25/29U; **Fiat Kobelco** E 20SR/E 20.2SR/E 22SR/E 22.2SR/E 25SR; **Foredil** FM 24/FM 29; **Gehlmax** MAX 25/A 25SA/M B 288; **Hanix** H 22A/H 22B; **Hinowa** VT 2000; **Hitachi** ZX 25/ZX 27U; **Ihi-Imer** 20J/2 0NX/25J/25NX/27J/28J/28N; **IMEF** HE 22.2/HE 2.25/HE 24/HE 28; JCB 1 CX/802/802.4; **Kamo** JUNIOR/MOBIL 18/25; **Kobelco** SK 2 0SR/SK 024/025/027/SK 20SR/SK 24/25SR/25SR.2/27SR.3; **Komatsu** PC 10/10.3/10.6/10.7/PC 12UU-1/PC 20MRX/PC 20R8; **Kubota** KH 027/KH 51/KH 66/KX 61/KX 61.2/KX 020/KX 022/U 20-3; **Libra** 125S; Macmoter M 2/M 2S; **Mazzotti** M AF 255/281/285; **Messersi** M 22U/M 25; MF 123/125/128; **Neuson** 1700RD/1702RD/1900/1901RD/1902RD/2200RD/2201RD/2202RD/2503RD/1903/2203; **New Holland** E 20.2/E 22.2/E 27.2SR; **Nissan** 220/250/260.2; **O&K** RH 2.1/2.3; **Pel Job** EB 16/EB 16.4/EB 16.22/EB 22/EB 200XT/EB 200 XTV/EC 20; **Takeuchi** B 020/TB 022/TB 23R/TB 025/TB 25FR/TB 28FR/TB 030/TB 125; **Venier** VF 1.33/VF 2.75; **Volvo** EC 25/EC 30/ECR 28; **Yanmar** B 19/B 22/B 25/B 25V/B 27/B 28/Vio 20; **YGR** 2500/SA 25 0/Y 22.

geeignet = für Bagger von 1,2 bis 3,5 t je nach Ausrüstung. Andere Klassen/Größen bedingt geeignet. Bei Bedarf bitte anfragen!